

iCentral™

Intelligent Central Systems

A DIVISION OF **NECF** CORPORATION



Four Plus Video Intercom System

OWNER'S MANUAL

Including Installation & Operation

Rev 1



Intelligent Central Systems

A DIVISION OF  CORPORATION

Central Vacuum
Intercom
Security
Automation

www.icentralsystems.com.au

SALES - SERVICE - SPARES

 **1300 050 333**

NESS HEAD OFFICE

 **02 8825 9222**

CONTENTS

FEATURES	4
SPECIFICATIONS	4
MONITOR DESCRIPTION	5
MONITOR DESCRIPTION - REAR	6
MONITOR DESCRIPTION - CONNECTIONS	7
SYSTEM DIAGRAM	8
INSTALLATION GUIDE	9
DIAGRAM 1 - 1 MONITOR, 1 DOORBELL	10
DIAGRAM 2 - 1 MONITOR, 2 DOORBELLS	10
DIAGRAM 3 - 4 MONITORS, 2 DOORBELLS.....	11
MONITOR INSTALLATION GUIDE	12
DOORBELL INSTALLATION GUIDE.....	13
CABLING GUIDE.....	14
DOOR LOCK CABLE SELECTION CHART.....	15
OPERATION GUIDE	16
MAIN MENU DESCRIPTION	17
INTERCOM - INTERNAL COMMUNICATION	17
CHIME SET - CHIME DURATION AND CHIME TYPE.....	18
VOLUME SET - CHIME, TALK AND CCTV	19
PHOTO SET - IMAGE CAPTURE FUNCTION	19
OTHER SET: UNLOCK TIME, DOOR 1, DOOR 2, CCTV NUM.....	21
HOW TO ANSWER THE DOOR BELL AND RELEASE THE DOOR LOCK?	22
HOW TO TRANSFER THE CALL FROM THE VISITOR?	22
HOW TO ADJUST BRIGHTNESS, CONTRAST AND COLOUR?.....	22
HOW TO MONITOR VIDEO AND AUDIO INPUTS?	23
HOW TO COMMUNICATE?	24
HOW TO BROADCAST A CALL?	24
IMAGE CAPTURE FUNCTION	25
USING AN SD CARD FOR IMAGE STORAGE.....	25
HOW TO ACTIVATE THE DO NOT DISTURB FUNCTION?.....	25
LED OPERATION	26

FEATURES

- Surface-mounted, 7 inch color TFT screen with sensor buttons
- Intercom, broadcast, call transfer among indoor monitors
- Supports up to 4 indoor monitors and 2 doorbell cameras
- Supports image capture function with 64 images memory
- Supports removable SD card for saving captured images to computer for history record
- Room-to-room internal communication
- Supports 4 CCTV cameras for security surveillance
- Can view 1 of 6 different video images from each indoor monitor at the same time
- Supports TV viewing & background music functions
- Adjustable Color/Contrast/Brightness/Volume
- Coaxial and 4-core shielded wiring

SPECIFICATIONS

■ Display screen	7 inch TFT
■ Scan frequency	15,625Hz(H)×50Hz(V)
■ Power voltage	AC 110~240V
■ Video input	75Ω 1Vp-p
■ Power consumption	1.5w ~16 w
■ Wiring mode	4 wires, polar
■ Applicable temperature	-10° C ~ 40 °C
■ Dimension	260 (W) × 195 (H) ×35(D)

MONITOR DESCRIPTION

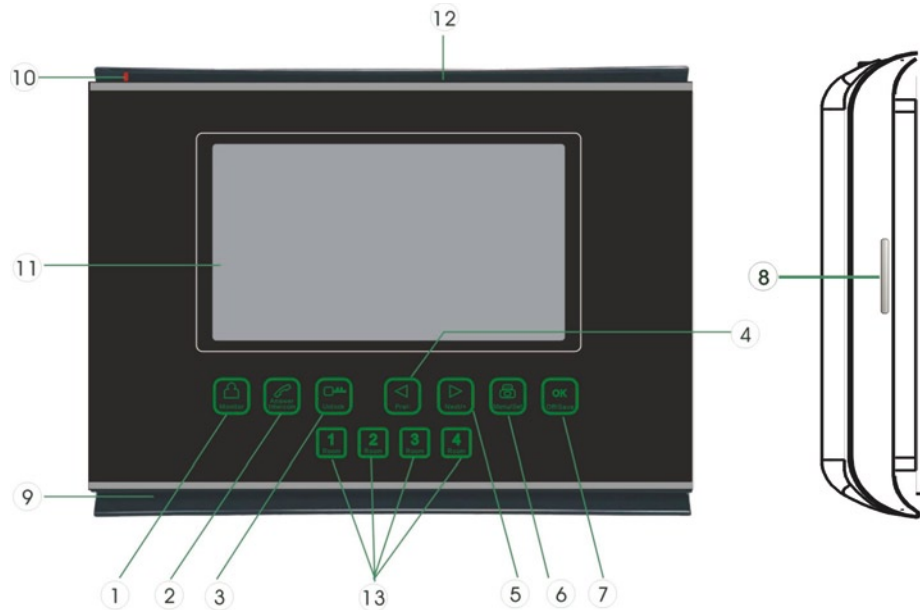

- 1-----Monitor
- 2-----Answer/Call transfer/Broadcast/Intercommunication
- 3-----Door Release
- 4-----Adjust Button (left)
- 5-----Adjust Button (right)
- 6-----Image Capture/Menu Set
- 7-----Off Button
- 8-----SD Card Slot
- 9-----Speaker
- 10-----Indicator Light
- 11-----7 Inch Screen
- 12-----Microphone
- 13-----Room to Room Call Buttons

DIMENSIONS

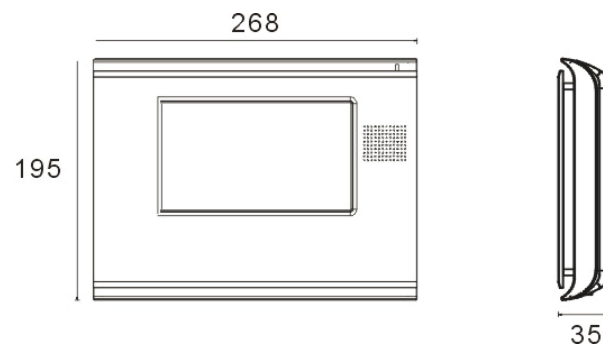

MONITOR DESCRIPTION - REAR

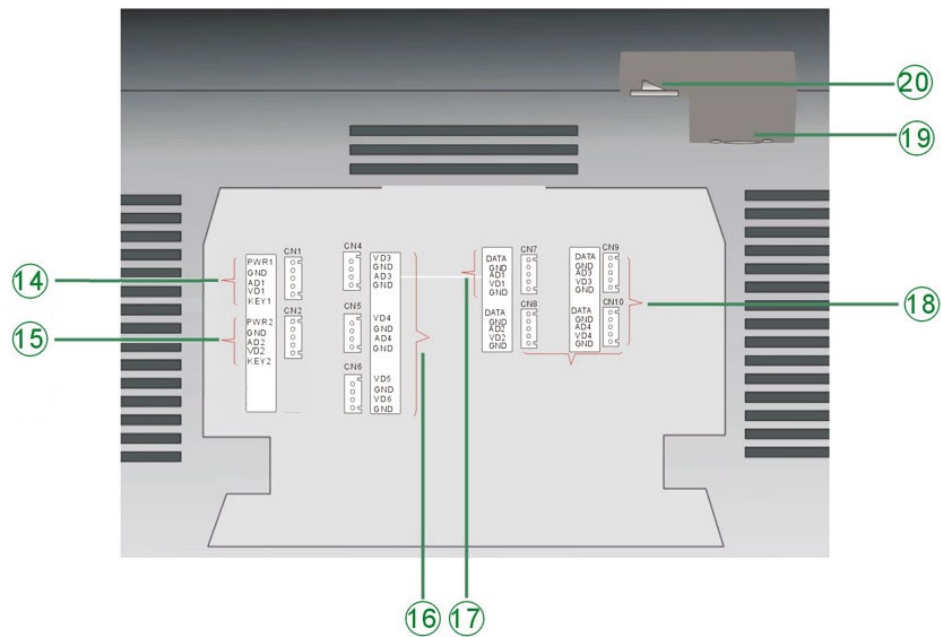

- 14-----Terminal for Door Bell 1
- 15-----Terminal for Door Bell 2
- 16-----Terminal for Extension Video/ Audio Line in
- 17-----Terminal for Main Monitor (ROOM1)
- 18-----Terminal for Sub Monitor 2/3/4 (ROOM2, ROOM3, ROOM4)
- 19-----Power Input (110~240VAC)
- 20-----Power ON/OFF

MONITOR DESCRIPTION - CONNECTIONS

Detail Description:

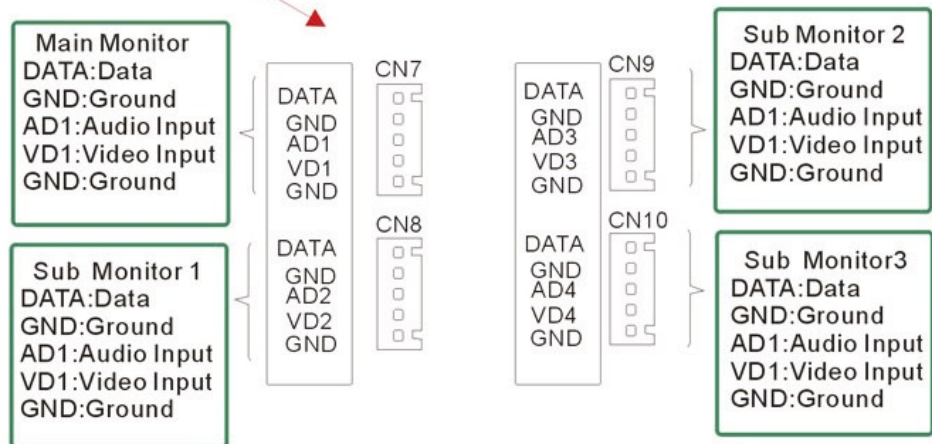
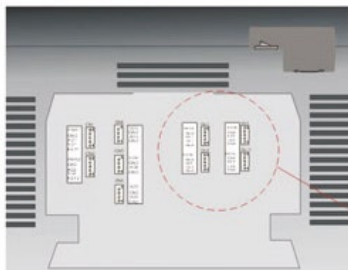
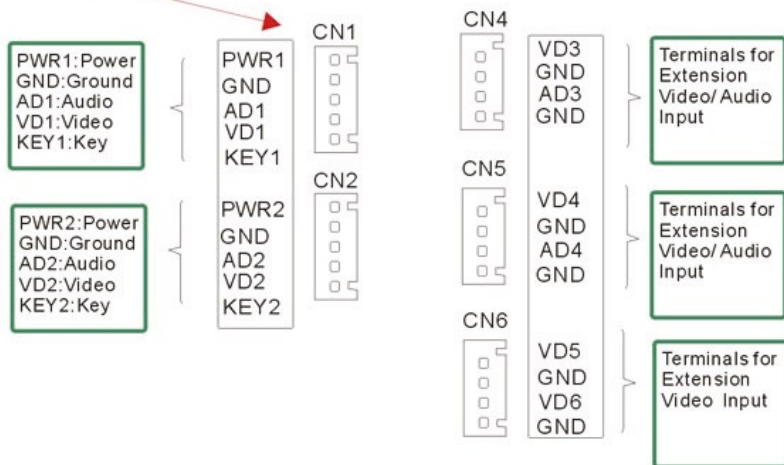
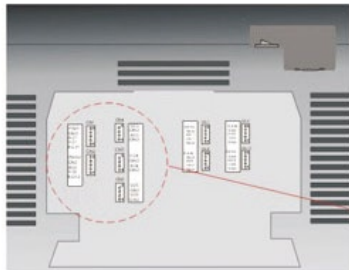

SYSTEM DIAGRAM

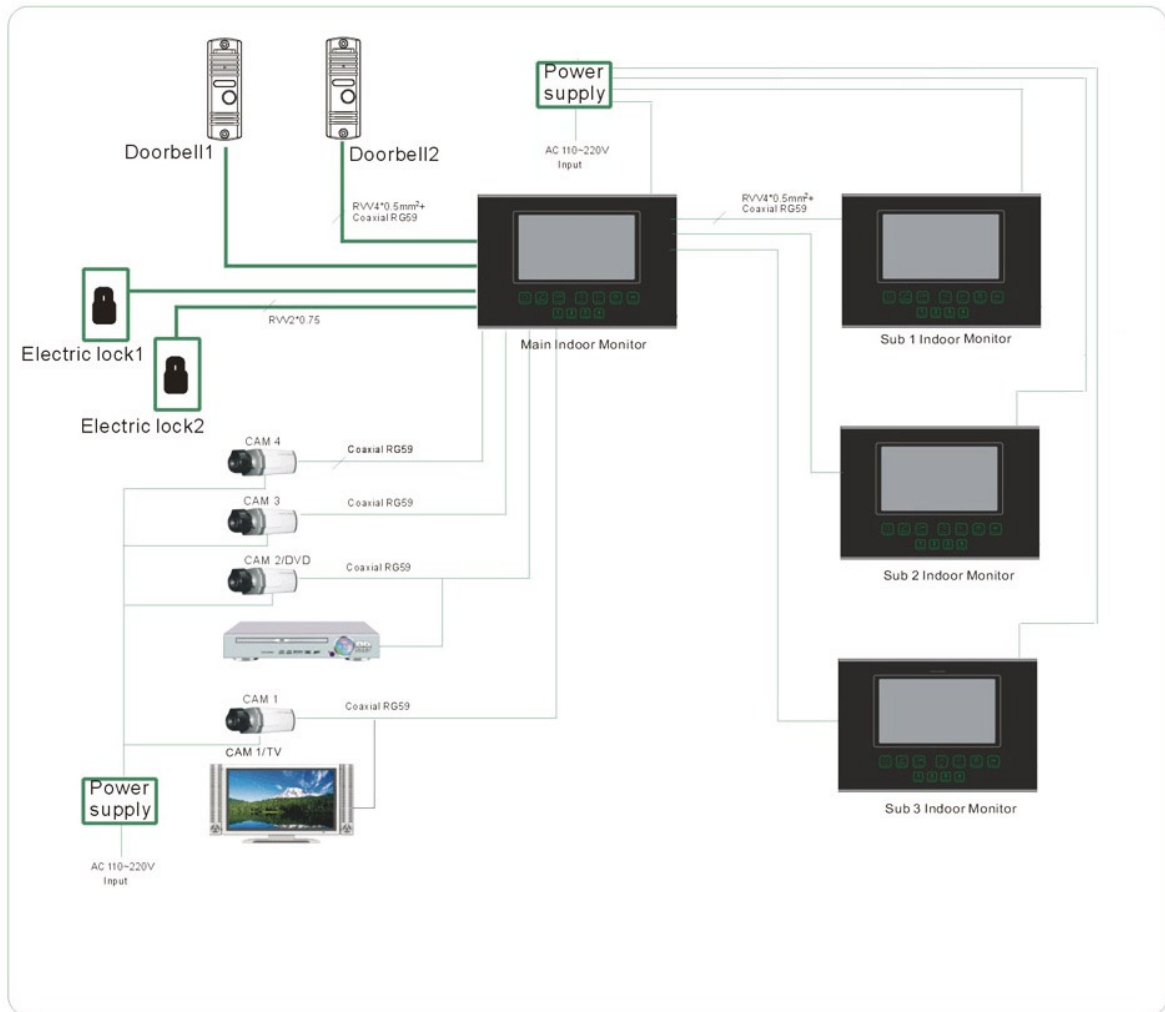

INSTALLATION GUIDE

DIAGRAM 1 - 1 MONITOR, 1 DOORBELL

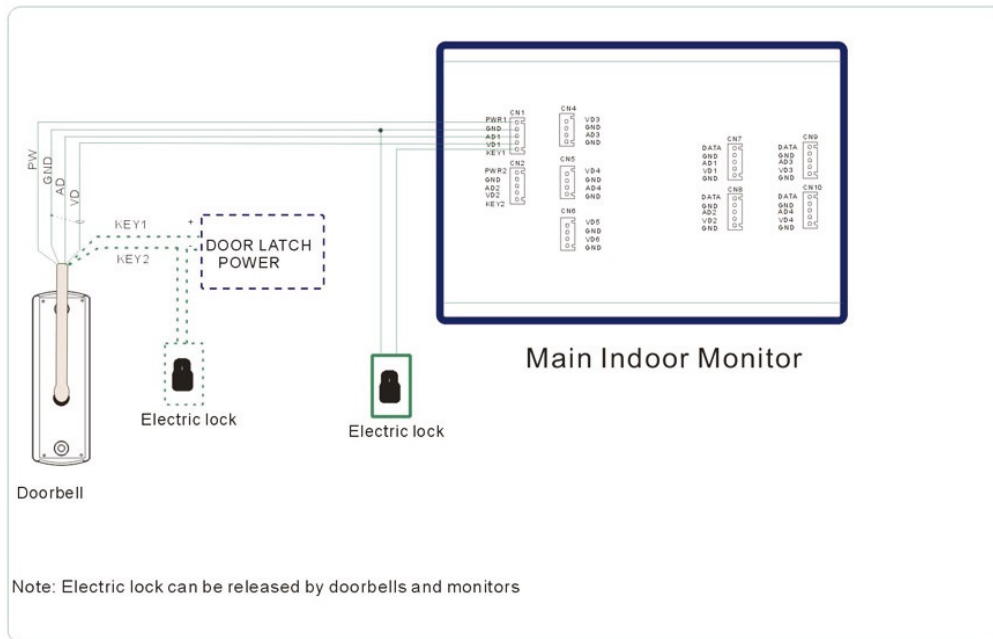

DIAGRAM 2 - 1 MONITOR, 2 DOORBELLS

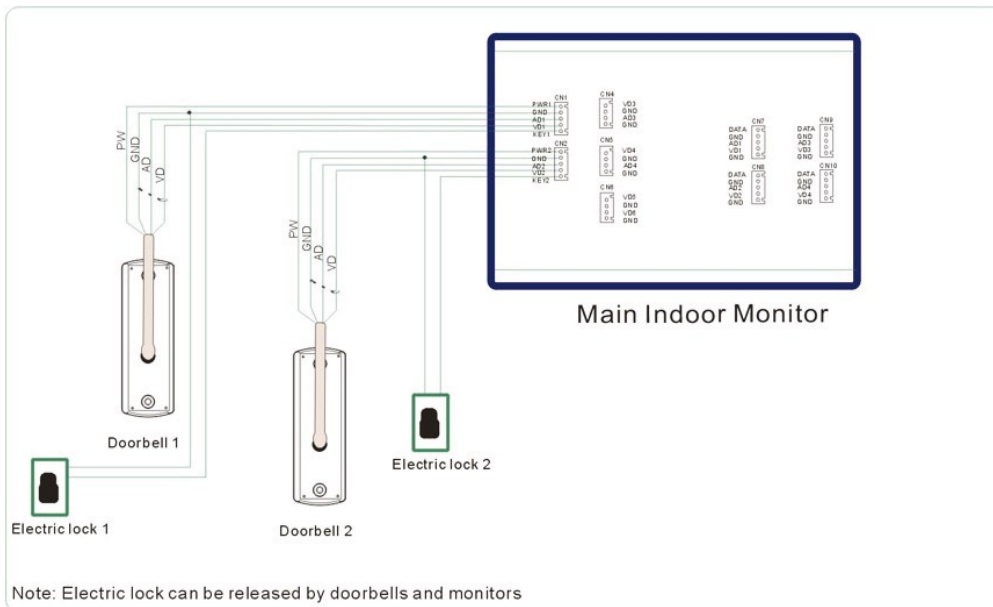
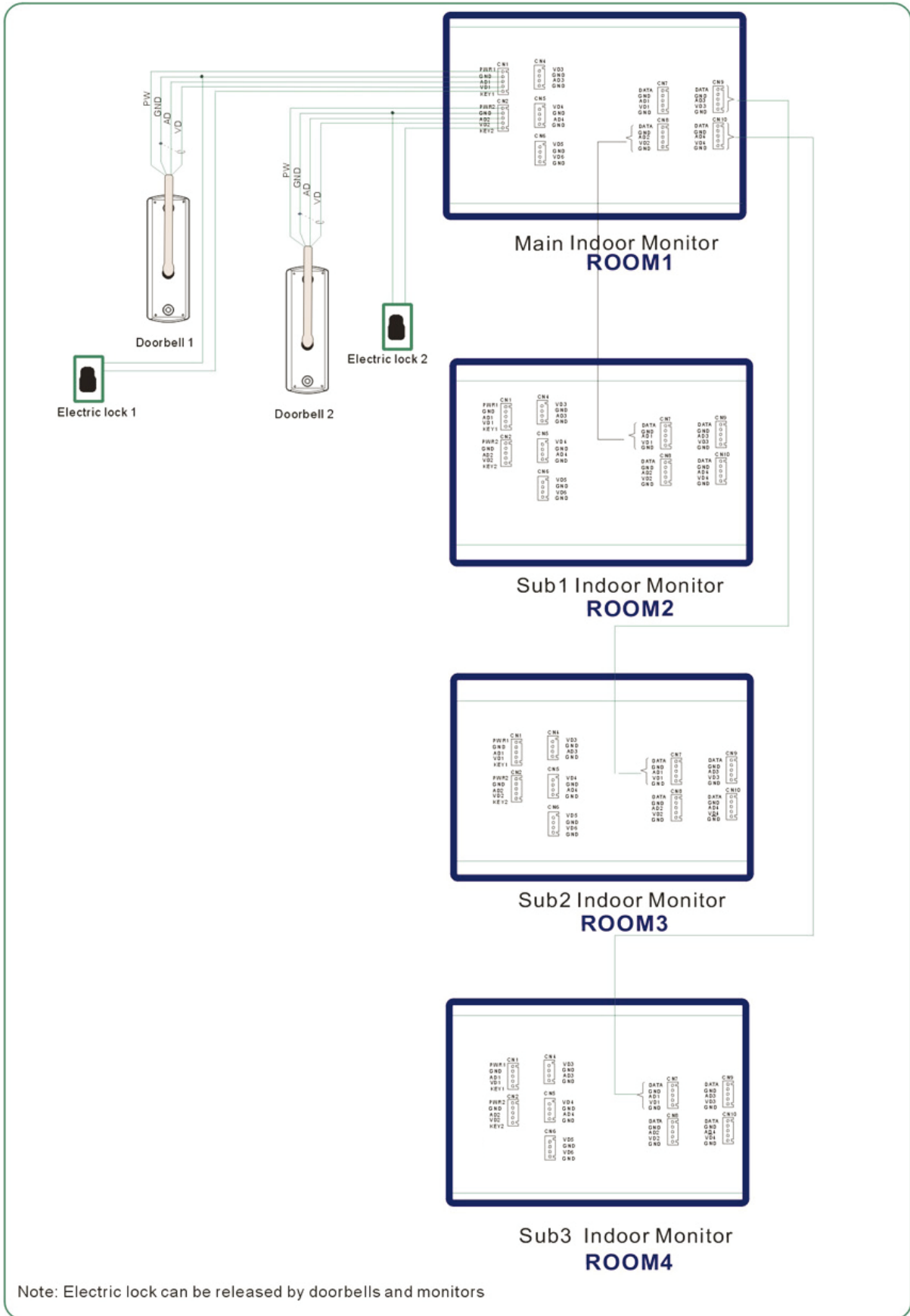

DIAGRAM 3 - 4 MONITORS, 2 DOORBELLS



Note: Electric lock can be released by doorbells and monitors

MONITOR INSTALLATION GUIDE

Indoor Monitor Installation

- Select the relevant wiring diagram from pages 8 and 9 that matches your installation requirement
- Ensure you have the correct cable according to the system's requirements
- Select correct height for the indoor monitor (generally 145-160cm)
- See Figure 1 below
- Next determine the position for the monitor bracket, run cable through the bracket and fix locating screws in bracket
- Connect cables to the rear of the indoor monitor according to the wiring diagrams on pages 8 and 9 in this manual
- Finally, install the indoor monitor on the wall as per Figure 2 below

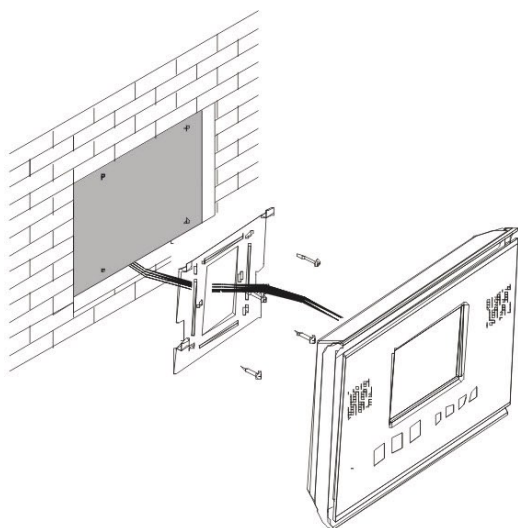

Figure 1

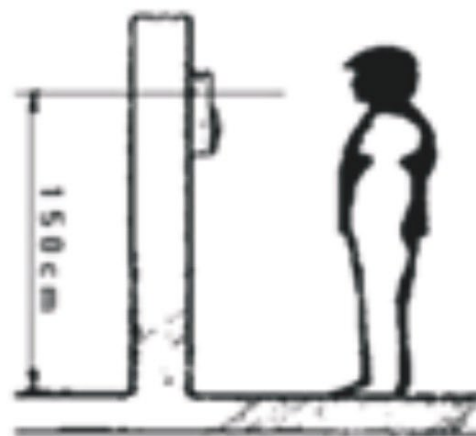
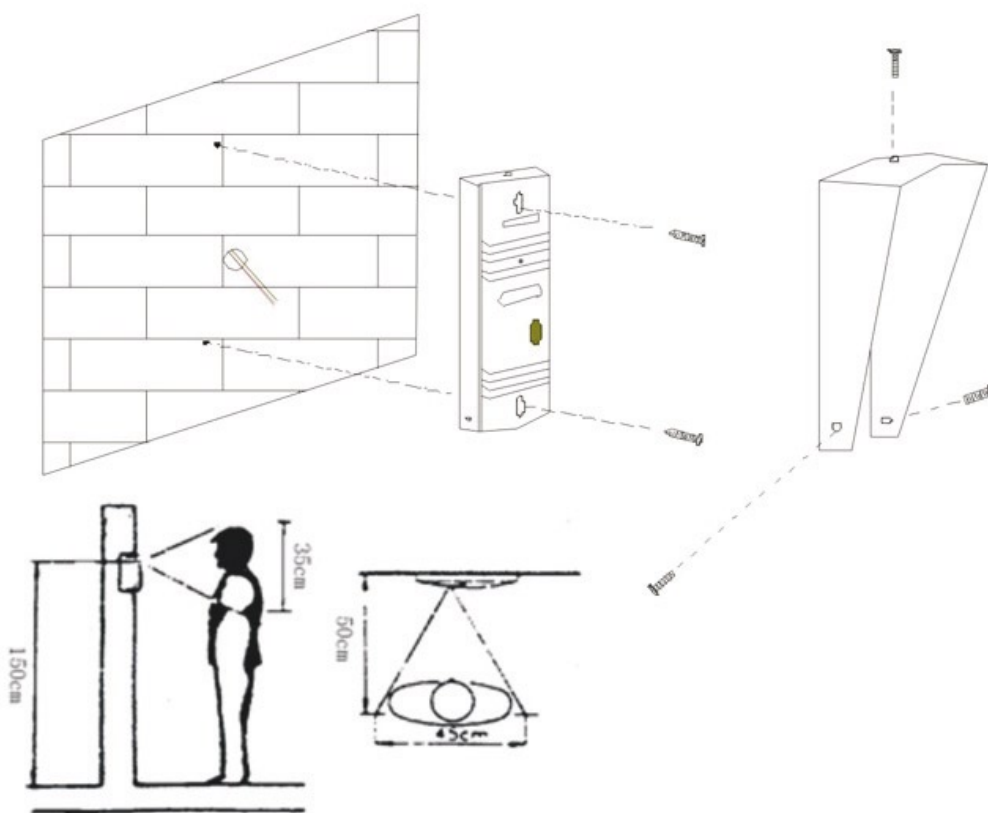

Figure 2

DOORBELL INSTALLATION GUIDE

Doorbell/Camera Installation

- Select the most suitable position for Doorbell/Camera.
- Consider factors such as day time operation, night time operation and impact of likely weather conditions.
- Direct sunlight on the camera and direct contact with rain should be avoided.
- Determine Camera Position: Recommended height of the camera is approximately 145 to 160 cm



CABLING GUIDE

(using RG59B/U Coaxial and 4 core shielded – 14/0.20)

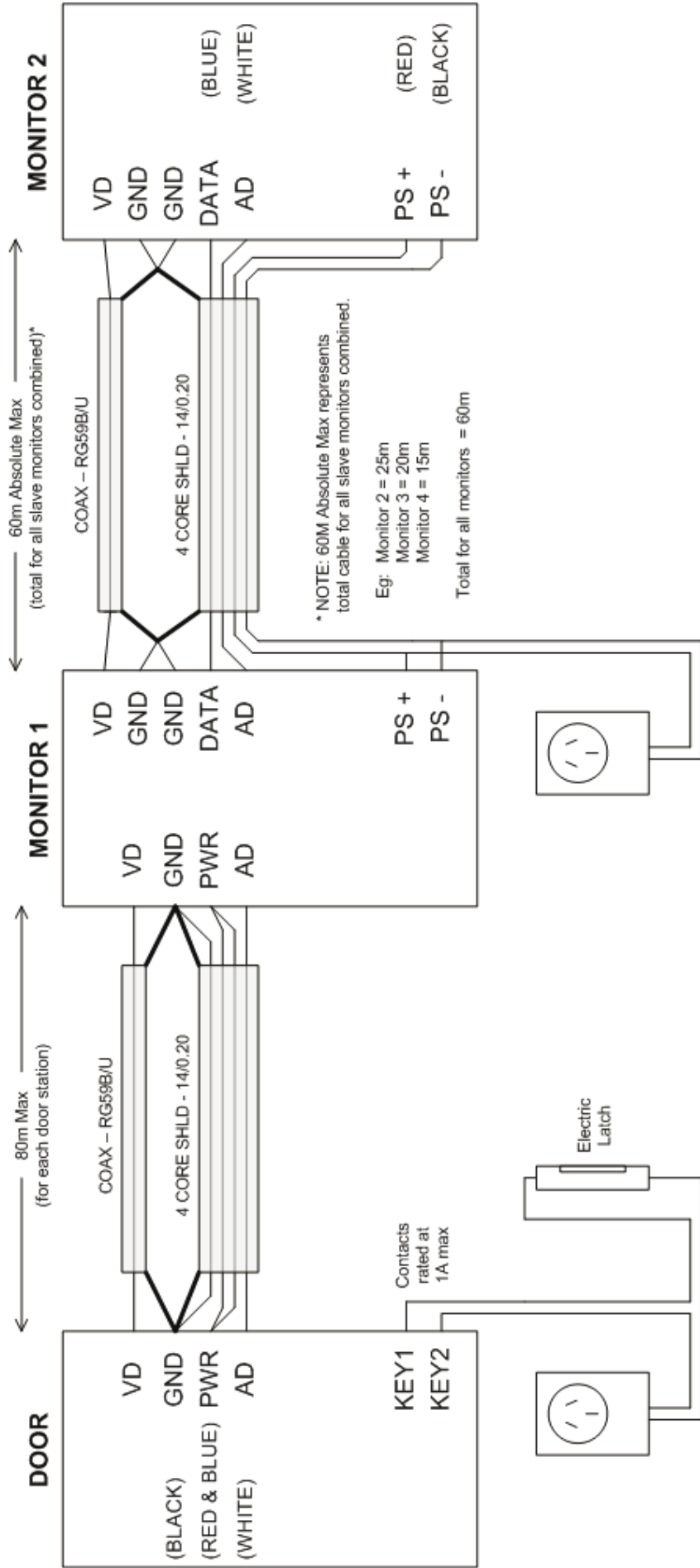

DOOR LOCK CABLE SELECTION CHART

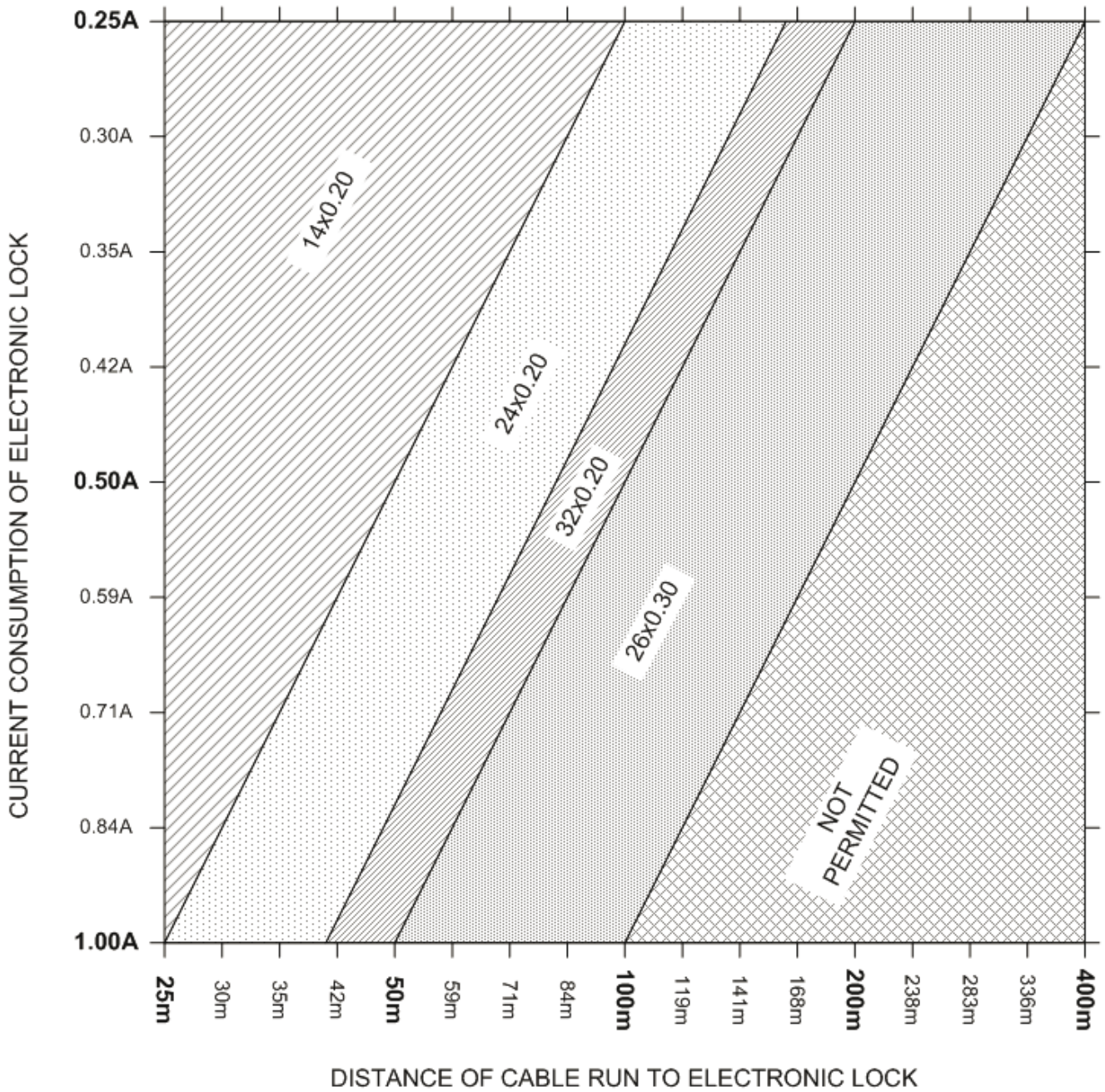

CABLE CHARACTERISTICS

14/0.020	0.4mm ²	0.043 Ω per metre *
24/0.020	0.75mm ²	0.025 Ω per metre *
32/0.020	1.0mm ²	0.019 Ω per metre *
26/0.030	1.8mm ²	0.010 Ω per metre *

The above chart allows for a maximum cable drop of 2 volt to the electronic lock using "Figure 8" wire with number and size of strands as recommended.

OPERATION GUIDE

MAIN MENU DESCRIPTION

In standby mode, press and hold the “MENU/SET” button for 2 seconds, to enter the main menu set-up interface as follows:

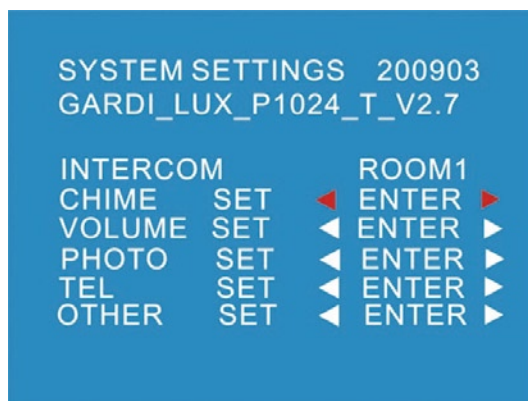

Press “MENU/SET” button to move cursor to the next sub item setup menu option.

Press “NEXT” button to enter the sub menu interface.

- Use “PREV” or “NEXT” buttons to modify the parameters in this interface
- Use “MENU/SET” button to select the next parameter

Press “OK” button to save and return to the main menu interface.

Press “OK” button again to exit the main menu and turn off the screen.

INTERCOM - Internal Communication

In the “SYSTEM SETTINGS” menu, each monitor must be set to a number, from ROOM-1 to ROOM-4, in order for intercommunication to take place. The main monitor must be set to ROOM-1 and the slave monitors must be set to ROOMS 2, 3 and 4.

Programming Procedure:

On entering the main menu, “ROOM1” will be highlighted in red.

Use “PREV” or “NEXT” buttons to select the desired Room number. The main monitor must be set to ROOM1 and the slave monitors must be set to ROOM2/ROOM3/ROOM4.

Press “OK” to save selection, exit “SYSTEM SETTINGS” menu and turn off screen.

CHIME SET - chime duration and chime type

The chime duration is adjustable from 10 to 30 seconds,

The Chime Type provides a choice of 10 different chimes for Door1, Door2, and intercom calls

Programming Procedure:

After entering the main menu interface, press the “Menu/Set” button to move the cursor to the “CHIME SET” option.

Press the ‘NEXT’ button, to enter the Chime Settings sub menu interface as follows:

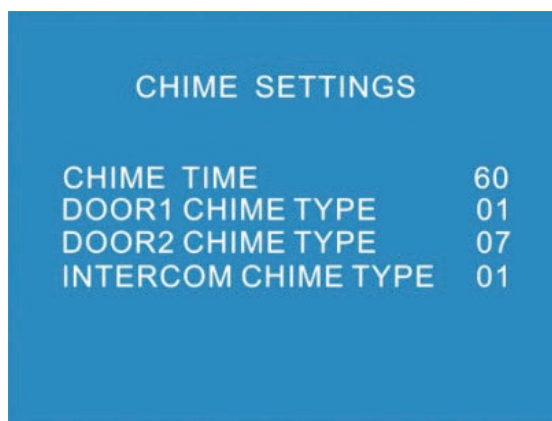

CHIME TIME: 10~30 seconds

DOOR1 CHIME TYPE: 10 chime chords for Door 1 (01~10)

DOOR2 CHIME TYPE: 10 chime chords for Door 2 (01~10)

INTERCOM CHIME TYPE: 10 chime chords for intercom calls (01~10)

Use “PREV” or “NEXT” buttons, to modify the parameters.

Press “MENU/SET” button to move the cursor to the next option.

Press “OK” button to save and return to the main menu.

Press “OK” button again, to exit the main menu and turn off the screen.

VOLUME SET - Chime, Talk and CCTV

Chime, Talk and CCTV volume can be set to High, Low or Mute.

Adjustment Procedure:

In the main menu, press the “Menu/Set” button to move the cursor to the “VOLUME SET” option,

Press the “NEXT” button to enter the VOLUME SETTING sub menu interface as follows:

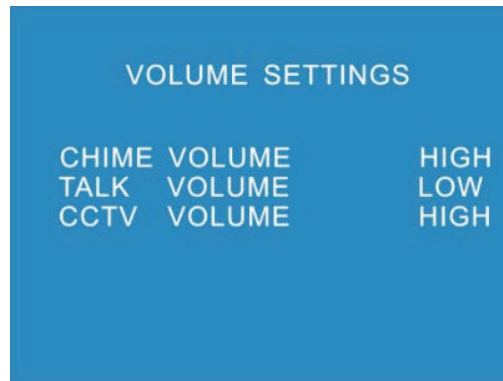

Use the “PREV” or “NEXT” buttons to modify the parameters

Press “Menu/Set” Button to move the cursor to the next option.

Press “OK” button to save and return to the main menu.

Press “OK” button again, to exit the main menu and turn off the screen.

PHOTO SET - Image capture function

(Enable, Disable, Time & Date and Image delete)

The image capture function can be enabled or disabled. System date and time will appear on captured images. All captured images can be deleted from indoor monitor.

Programming Procedure:

Enter the main menu and press “Menu/Set” button to move the cursor to the “PHOTO SET” option.

Press “NEXT” button, to display the image capture setup sub menu interface as follows:

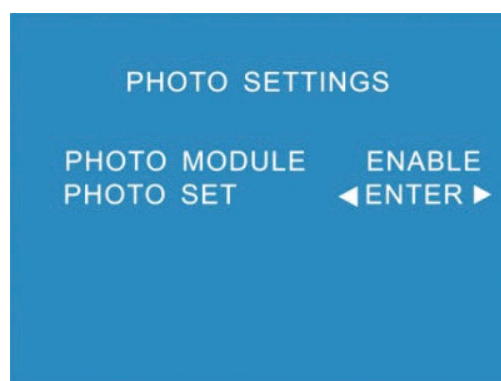

Use “Menu/Set button to select Photo Module option

Press “Next” button to Enable or Disable

ENABLE – Images will be recorded

DISABLE – Images will not be recorded

Use “Menu/Set button to select Photo Set option

Press “Next” button to Enter Photo Set sub menu as follows:

Note: Any one of the following windows may appear

Use “Menu/Set” button to navigate to “Time Setup/Format” window

PHOTO SET: Time setup and Image Delete setup.



Time setup

Date: YYYY/MM/DD

Time : HH/MM/SS

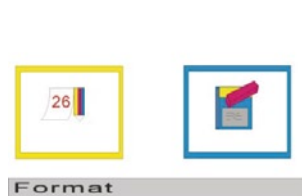

Delete images

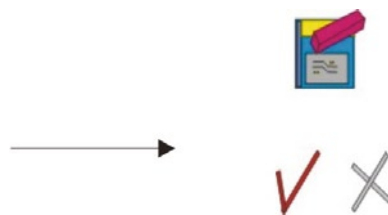

✓: Confirm deletion of all images
X: Cancel deletion of images

When in the “Time Setup/Format” window, use “Next” button to switch between “Time Setup” and “Format”

With “Time Setup” selected, use the “Menu/Set” button to move to next parameter.

Use “Prev” or “Next” buttons, to modify the parameters.

When Date and Time successfully programmed, use the “OK” button to navigate back through previous menus and exit or use the “Menu/Set” button to return to the “Time Setup/Format” window.

With “Format” selected, use the “Menu/Set button to move to the “Image Delete” confirmation window.

Use the “Prev” and “Next” buttons to Confirm or Cancel deletion of images.

Use the “OK” button to navigate back through previous menus and exit or use the “Menu/Set” button” to return to the “Time Setup/Format” window.

OTHER SET: Unlock Time, Door 1, Door 2, CCTV Num

UNLOCK TIME, for Door Unlock function, can be preset from 1 to 9 seconds.

Door 1 and Door 2 can be individually ENABLED or DISABLED

If you only install one doorbell, you will only need to activate Door 1. If you install 2 doorbells, you should enable both door 1 and door 2.

“CCTV NUM” indicates the number of surveillance cameras (max of 4) that are connected to the system. If there are no cameras connected, set “CCTV NUM” as “00”. If you don’t install any cameras and do not set this number to “00”, the indoor monitors will display a blue screen when you view any of the CCTV channels.

Programming Procedure:

From the main menu, press the “Menu/Set” button to move the cursor to the “OTHER SET” option.

Click the “Next” button to enter the “Other Settings” sub menu as below:

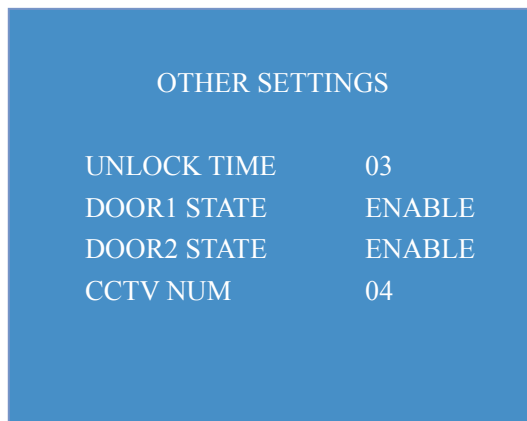

OTHER SETTINGS	
UNLOCK TIME	03
DOOR1 STATE	ENABLE
DOOR2 STATE	ENABLE
CCTV NUM	04

UNLOCK TIME:	Lock release time (01 – 09 seconds)
DOOR1 STATE:	Door 1 channel (ENABLE/ DISABLE)
DOOR2 STATE:	Door 2 channel (ENABLE/DISABLE)
CCTV NUM:	CCTV channels (00 – 04)

Use the “Prev” or Next” button, to modify the parameters.

Press the “Menu/Set” button to move the cursor to the next option.

Press the “OK” button to save and return to the main menu.

Press the “OK” button again to turn off the screen and exit.

How to answer the door bell and release the door lock?

When a visitor presses the doorbell button, all indoor monitors will chime.

The screen will display an image from the door camera, a description “DOOR 1” or “DOOR 2” and a message “PLEASE TAKE UP”.

At this time you can see the visitor, know if the call is from door 1 or door 2 and answer the call.

Press the “Answer Intercom” button to speak with the visitor.

The call will self-cancel after 60 seconds or you can Press the “OK” button to end the call.

Press the “UNLOCK” button to release the door lock. The message “UNLOCKED” will appear on the screen.

How to transfer the call from the visitor?

A call may be transferred to another monitor in one of the following two ways:

1. Direct transfer

After you answer the call, press the “Answer Intercom” button again. (If you know the room number you wish to transfer to, press the room number button instead of the “Answer Intercom” button)

The message “CALL TRANSFER REQUEST” will appear on the screen.

The Chime will sound and the message “PLEASE TAKE UP TRANSFER”, will display on the receiving monitors.

Press the “Answer Intercom” button at the receiving monitor to answer the call.

2. Broadcasting transfer

After you answer the call, press the “Answer Intercom” button again. Before anybody answers the call, you can speak into the microphone and broadcast to all other indoor monitors. Once any indoor monitor responds the call, the other monitors will auto cancel. The conversation time is 60 seconds or can be terminated at any time by pressing the “OK” button.

How to adjust Brightness, Contrast and Colour?

In intercom or surveillance mode, with an image on the screen, press and hold the “Prev” or “Next” button for 2 Seconds to display the “Brightness” level.

Use the “Prev” or “Next” button to adjust the Brightness to the desired level.

With the Brightness level displayed, press the “Menu/Set” button to display the “Contrast” level.

Use the “Prev” or “Next” button to adjust the Contrast to the desired level.

With the Contrast level displayed, press the “Menu/Set” button to display the “Colour” level. Use the “Prev” or “Next” button to adjust Colour to the desired level.

Press the “OK” button to save settings and exit.

How to monitor Video and Audio Inputs?

There are six Audio/Video channels that can be viewed individually at any of the indoor monitor units at any time.

The first two channels are Door-1 and Door-2 and provide both video and audio signals from each of the doorbell units.

The next two channels are CCTV-1 and CCTV-2 which can be used for Audio, Video or both. The next two channels are CCTV-3 and CCTV-4 which are purely for Video.

CCTV-1 to CCTV-4 can all be used for surveillance cameras however because CCTV-1 and CCTV-2 include inputs for **audio** as well as **video**, these two inputs can be used for television, background music or cameras equipped with microphones.

Note: Inputs for CCTV-1 are VD3 (Video) and AD3 (Audio)

Inputs for CCTV-2 are VD4 (Video) and AD4 (Audio)

Input for CCTV-3 is VD5 (Video)

Input for CCTV-4 is VD6 (Video)

- 1 Press the “Monitor” button, to see image and hear sound from Door-1.
- 2 Press the “Monitor” button again, to see image and hear sound from Door-2.
- 3 Press the “Monitor” button again, to see image and hear sound from CCTV-1.
- 4 Press the “Monitor” button again, to see image and hear sound from CCTV-2.
- 5 Press the “Monitor” button again, to see image from CCTV-3.
- 6 Press the “Monitor” button again, to see image from CCTV-4.

When Door-1 or Door-2 is being monitored, the image and sound will remain active at the monitor unit for 30 seconds and then reset.

When CCTV 1, 2, 3 or 4 are being monitored, the image and sound (if applicable) will remain until the function is turned off.

Note: If the chime is activated at one of the door units, while monitoring any of the other Audio/Video channels, the screen will automatically change to the visitor’s doorbell channel.

The call can be answered as normal and when the call is terminated, the system will automatically return to the previous channel being monitored.

How to communicate?

There are two ways to communicate between monitors:

1. Call all monitor stations

Press the “Answer Intercom” button at a monitor station

- The chime will activate at all monitor stations
- “All” and “Intercom Request” will be displayed at the calling station
- The Room Number of the calling station and “Please Take Up” will be displayed at all receiving stations.

Press the “Answer Intercom” button at any monitor station to answer the intercom call.

2. Call individual monitor station

Press one of the number buttons (1-4) at a monitor station

- The chime will activate at the calling station and corresponding receiving station
- The Room Number of the station being called and “Intercom Request” will be displayed at the calling station
- The Room Number of the calling station and “Please Take Up” will be displayed at the receiving station.

How to broadcast a call?

A call can be broadcast throughout the entire house as, for example, when dinner is ready.

Press and hold the “Answer Intercom” button for 2 seconds

- The words “All” and “Broadcast Message” will display at the broadcasting station
- The receiving stations will sound an annunciation beep.
- The receiving stations will also display “Broadcasting” and the Room Number of the broadcasting station.

After the annunciation beeping has stopped, simply speak to broadcast your message to all other monitor stations.

The broadcast will auto-cancel after 30 seconds or can be terminated by pressing the “OK” button

Image Capture function

1. Auto Capture: If the door chime is activated by a visitor but no one replies from any of the monitor units, the system will take an image of the visitor and store it for later viewing. Up to 64 images, with date/time stamp, can be stored. When image storage is full, the oldest image is deleted each time a new image is added.

2. Manual Capture: When you monitor an image or talk with a visitor at the door station, press the “Menu/Set” button. The message “IMAGE CAPTURED” will appear on the screen indicating that the visitor’s image has been successfully captured.

Press “Menu/Set” while in standby mode to view the last captured image.

Use the “Prev” or “Next” buttons to view other images.

Using an SD Card for image storage

Images are normally stored using the on-board memory however images can also be stored on a removable SD card allowing images to be transferred to a personal computer.

The maximum capacity of SD card is not to exceed 1 GB

The SD card must be formatted using the “Image Delete” process in the Photo Set menu.

IMPORTANT NOTE:

Do not format the SD card on a personal computer as the SD card will no longer be suitable for use with the intercom and will need to be replaced with a new card.

The SD card must only be formatted using the “Image Delete” process in the Photo Set menu.

How to activate the Do Not Disturb function?

When you don’t want to be disturbed by the chime from an indoor monitor, you can activate the Do Not Disturb function. There will be no sound from the monitor when the doorbell is activated or when an all station call is initiated. The chime will only sound when the monitor receives an individual call from another monitor where the call has been initiated using the appropriate “NUMBER” button.

Activation procedure:

In standby mode, press the “Monitor” button for 2 seconds at any indoor monitor.

“No Disturb Mode On” will appear on the screen. In Do Not Disturb mode, the monitor can still see the image from the front door and can still answer the call.

Do Not Disturb mode can be deactivated by once again pressing the “Monitor” button for 2 seconds while in standby mode. “No Disturb Mode Off” will appear on the screen.

LED Operation

LED STATUS	
Red Light On	Standby Mode
Green Light On	Communication Mode
Blue Light On	Captured Images Not Yet Viewed
Red Light Flashing	Standby in Do Not Disturb Mode
Green Led Flashing	Communication in Do Not Disturb Mode
Blue Led Flashing	Captured Images Not Yet Viewed In DND Mode



iCENTRAL FOUR PLUS INTERCOM OWNERS MANUAL
REV 1, November 2009

Document Part Number: 890-404



COPYRIGHT NOTICE

All rights reserved. No part of this publication may be reproduced, transmitted or stored in a retrieval system in any form or by any means, electronic, mechanical, photocopying, recording, or otherwise, without the prior written permission of Ness.

Ness reserves the right to make changes to features and specifications at any time without prior notification in the interest of ongoing product development and improvement.

© 2009 Ness Security Products Pty Ltd ABN 28 069 984 372